

**fablab**  
**NEUCH**  
fablab-neuch.ch

schema 3D: migbot.com

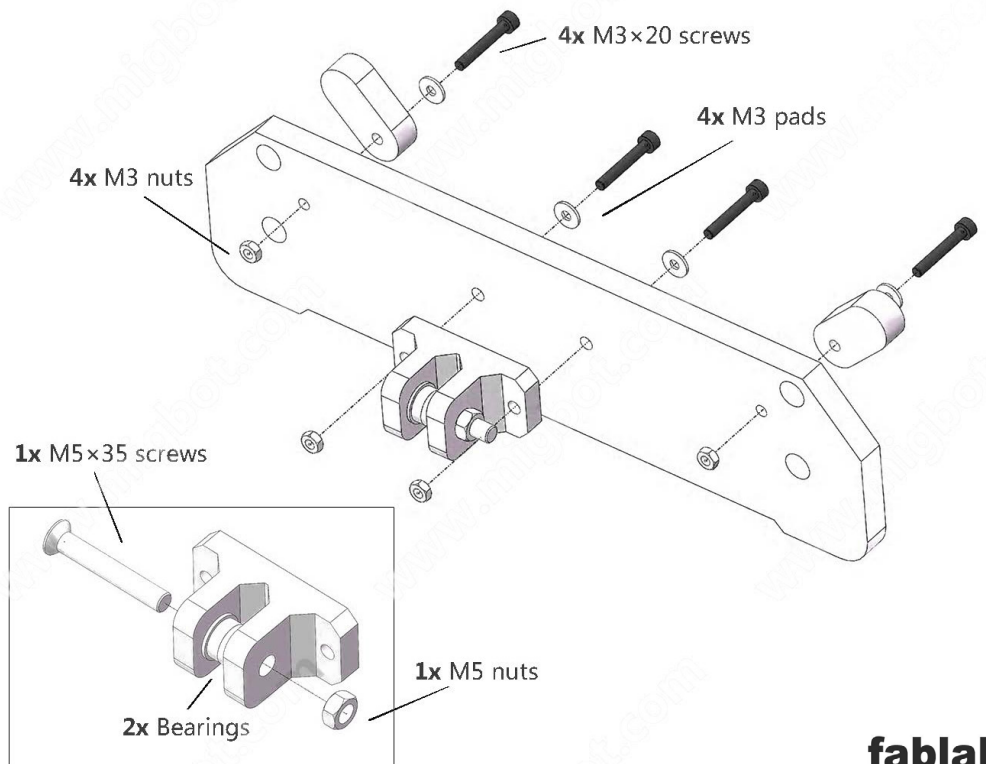

4x M3 x 20mm + écrous + rondelles



1

2x M3 x 20mm + écrous + rondelles  
 2x M3 x 16mm + écrous + rondelles  
 4x M3 x 12mm

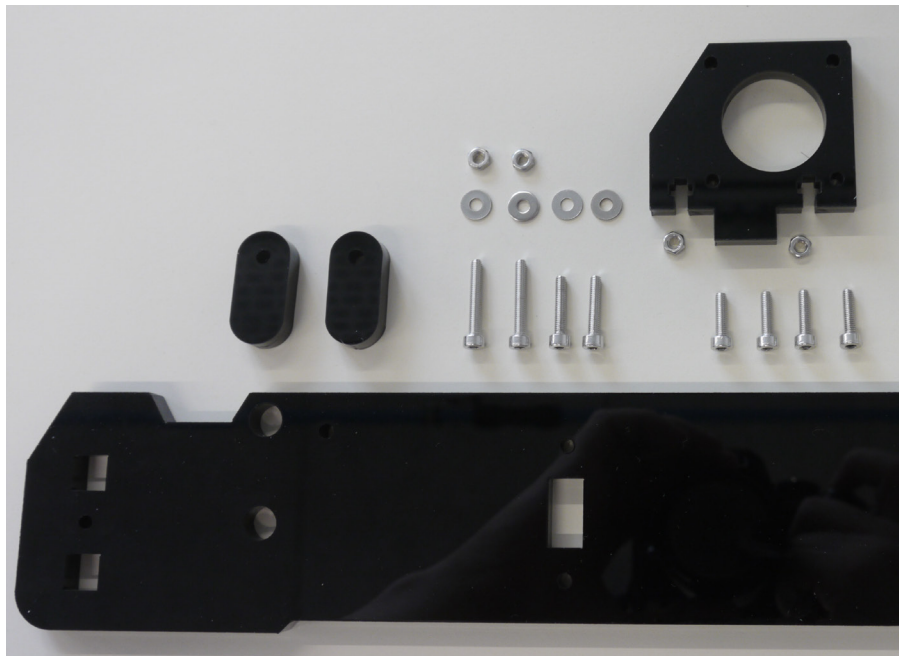

**Positionnez la connectique correctement**

**Attention à la position de la poulie**

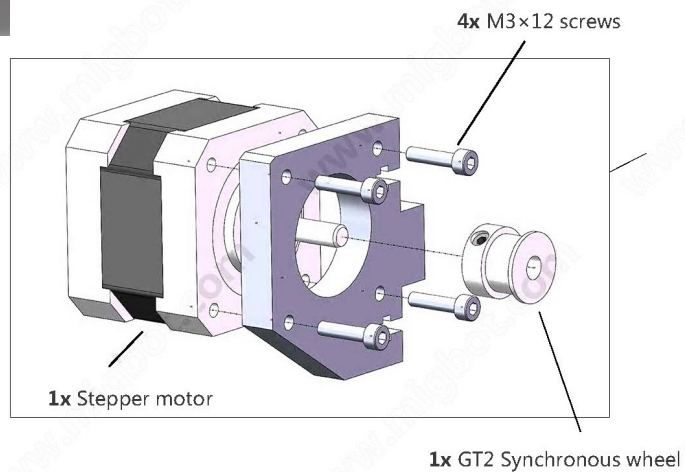
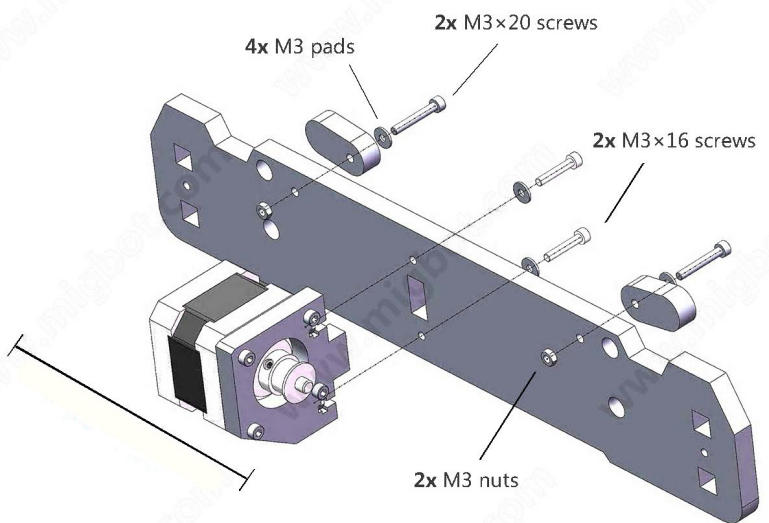
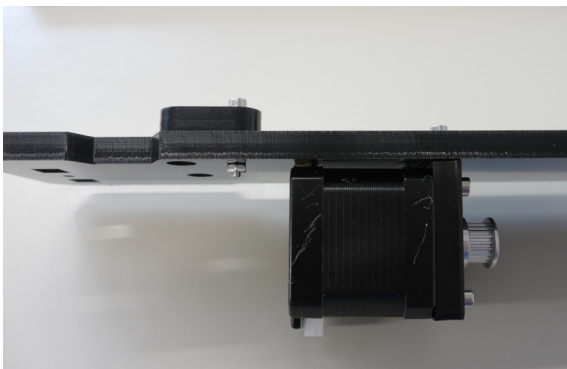
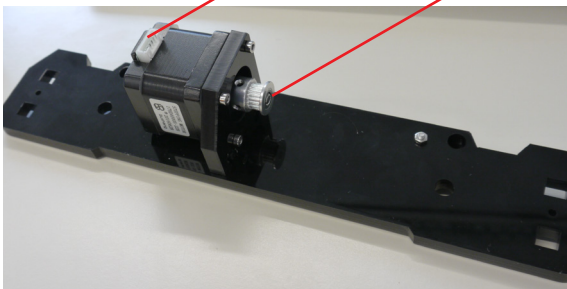

2



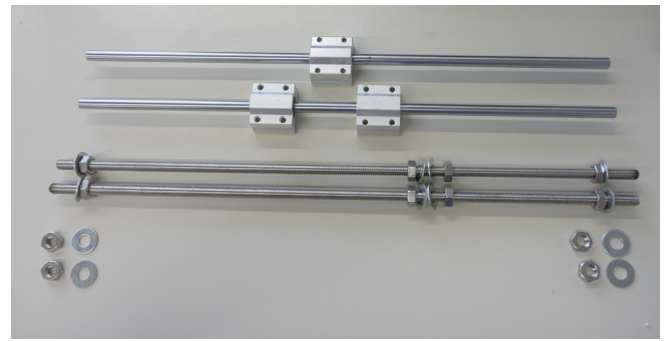
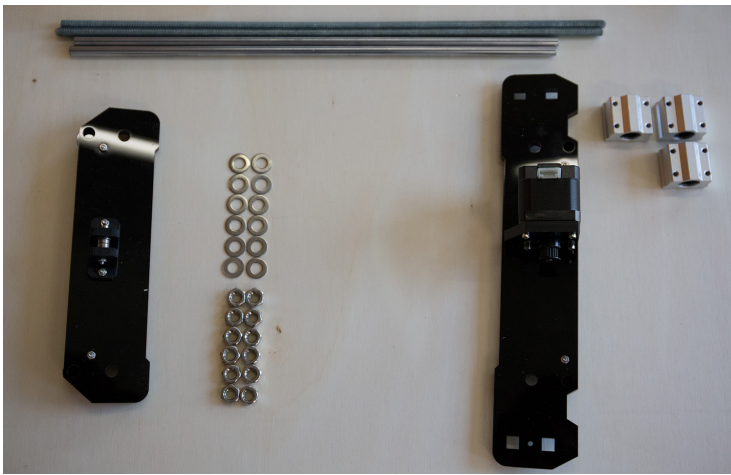

12x écrous M8 x rondelles  
 2x tiges lisses  
 2x tiges filetées

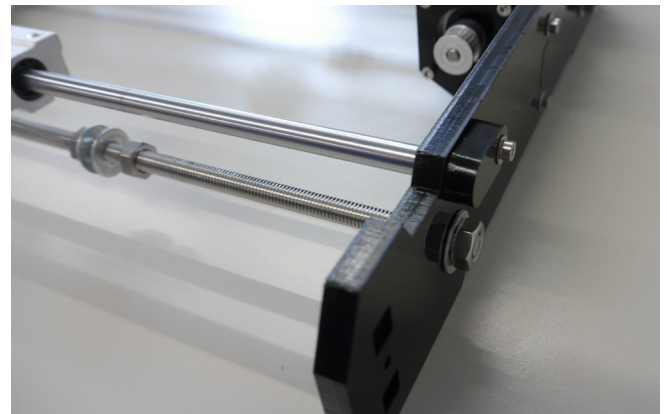
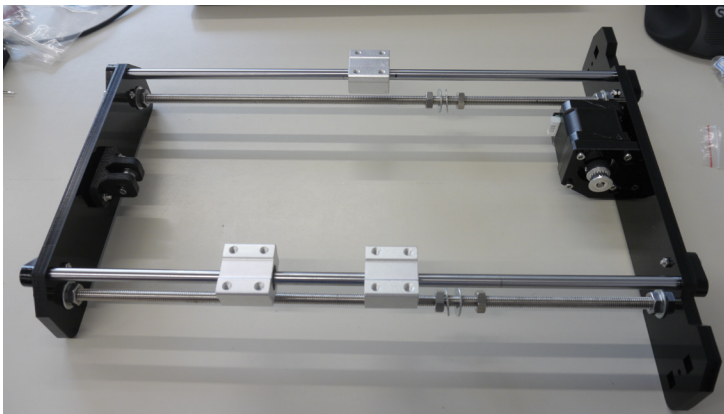

Utilisez toute la longueur des tiges!

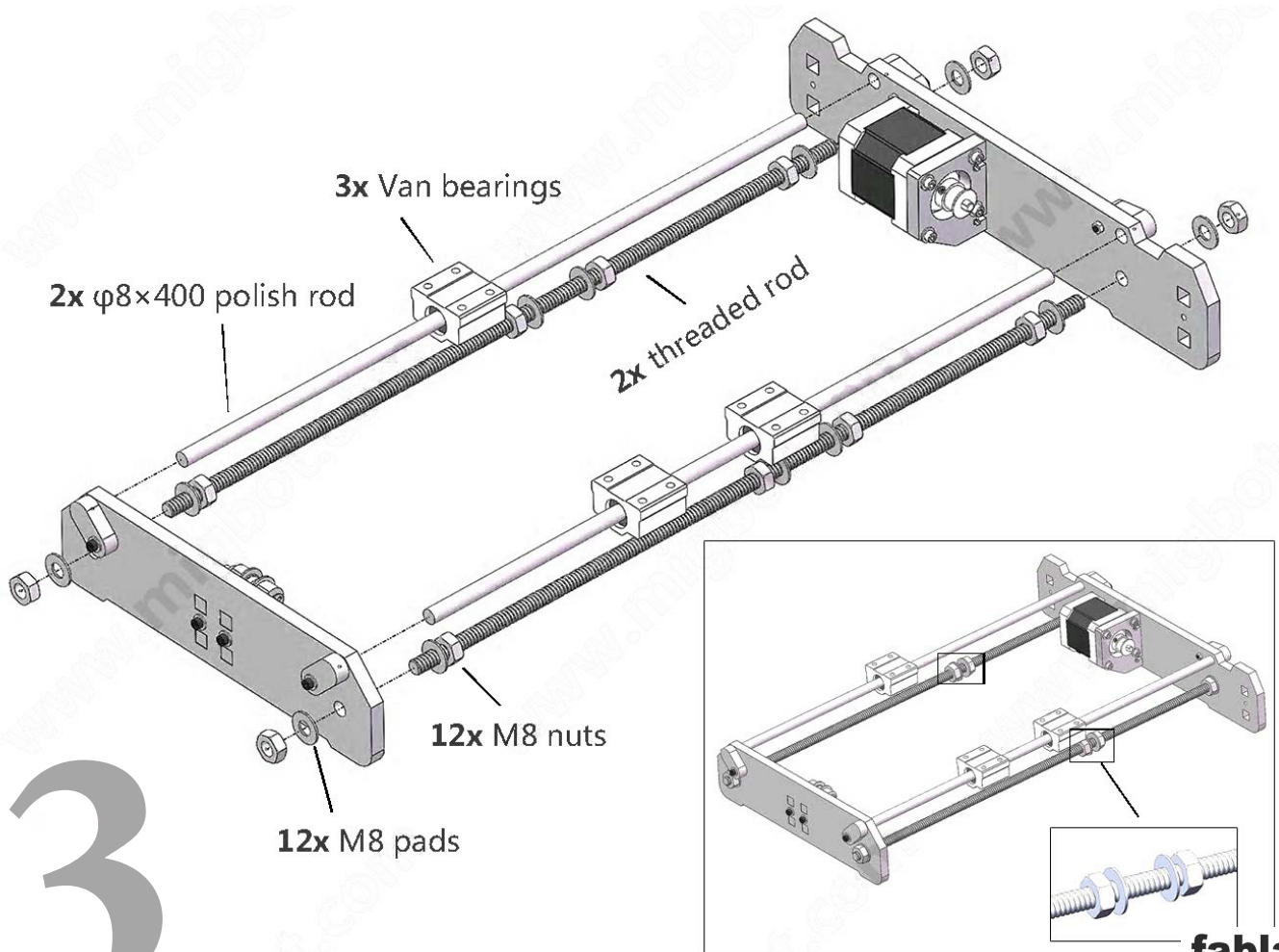

3



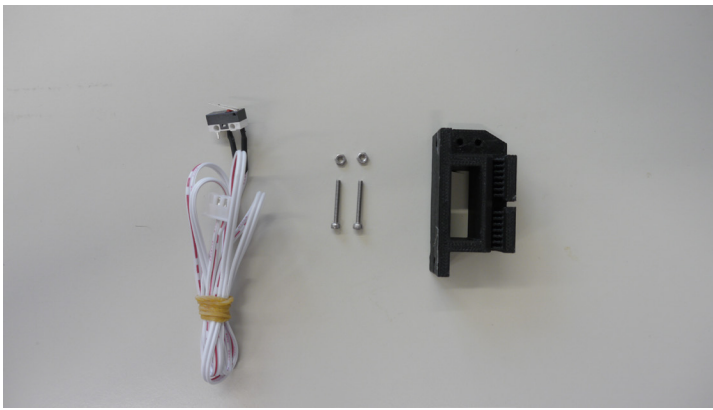

2x M2 x 16mm + écrous

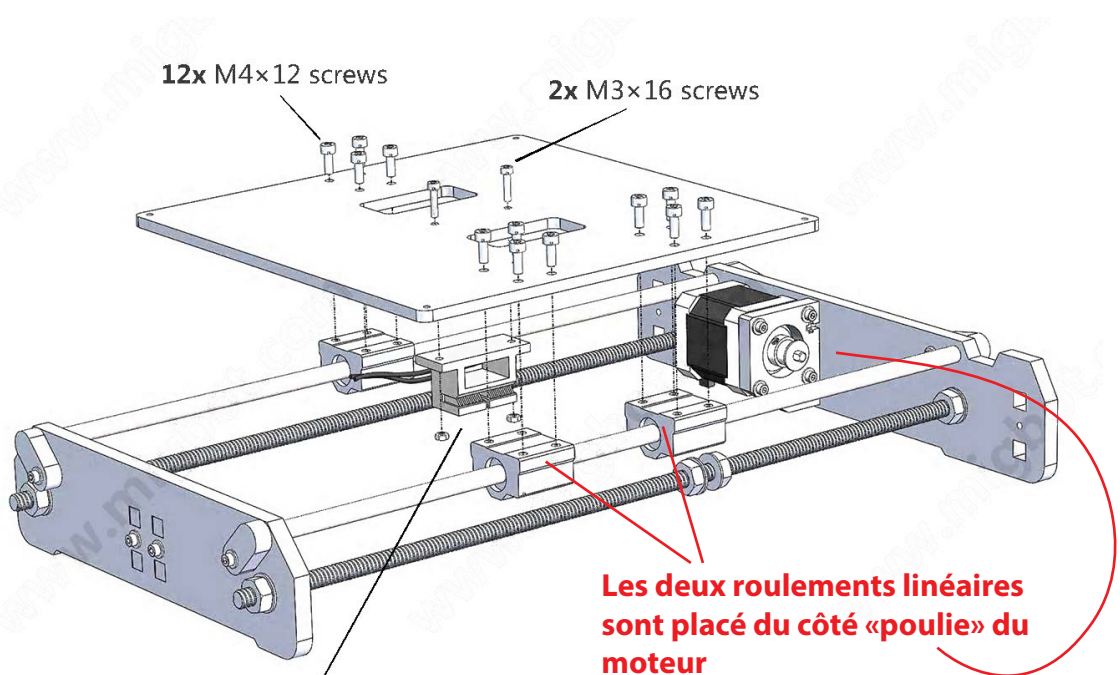
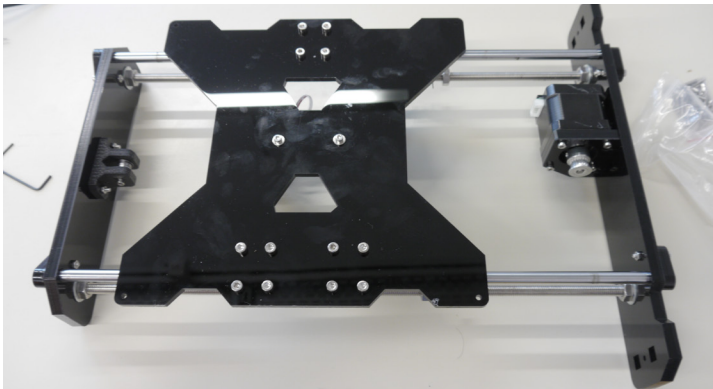

Fixez le capteur de fin de course avant de fixer le support sur le plateau

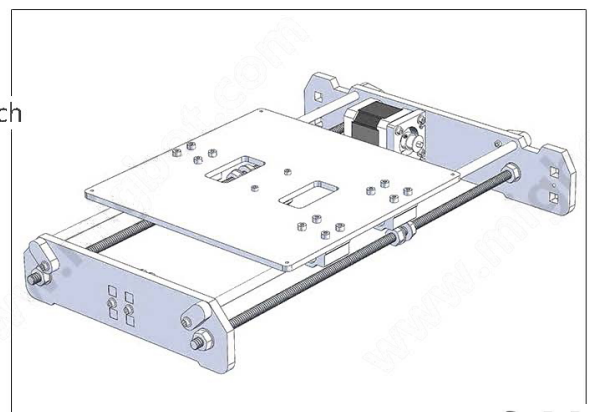
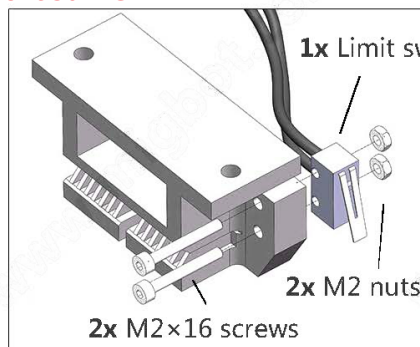

4

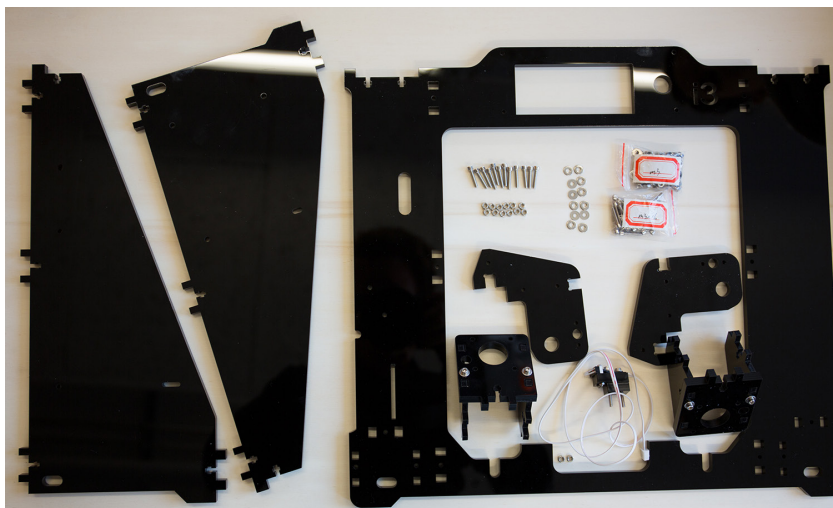

- 16x M3 x 16mm + écrous + rondelles
- 2x M2 x 16mm + écrous
- 2x M3 x 30mm + écrous + rondelles

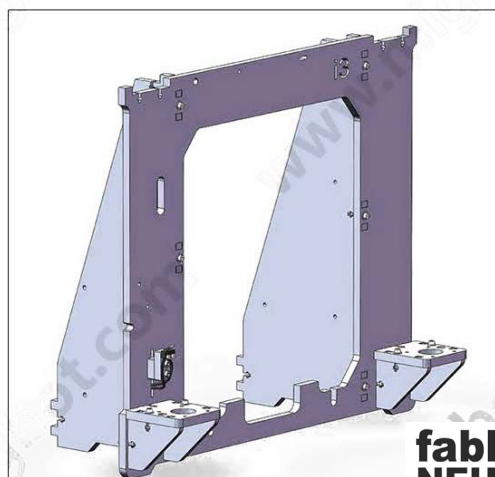
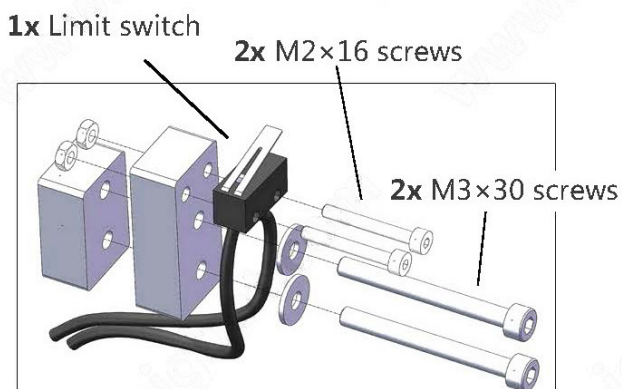
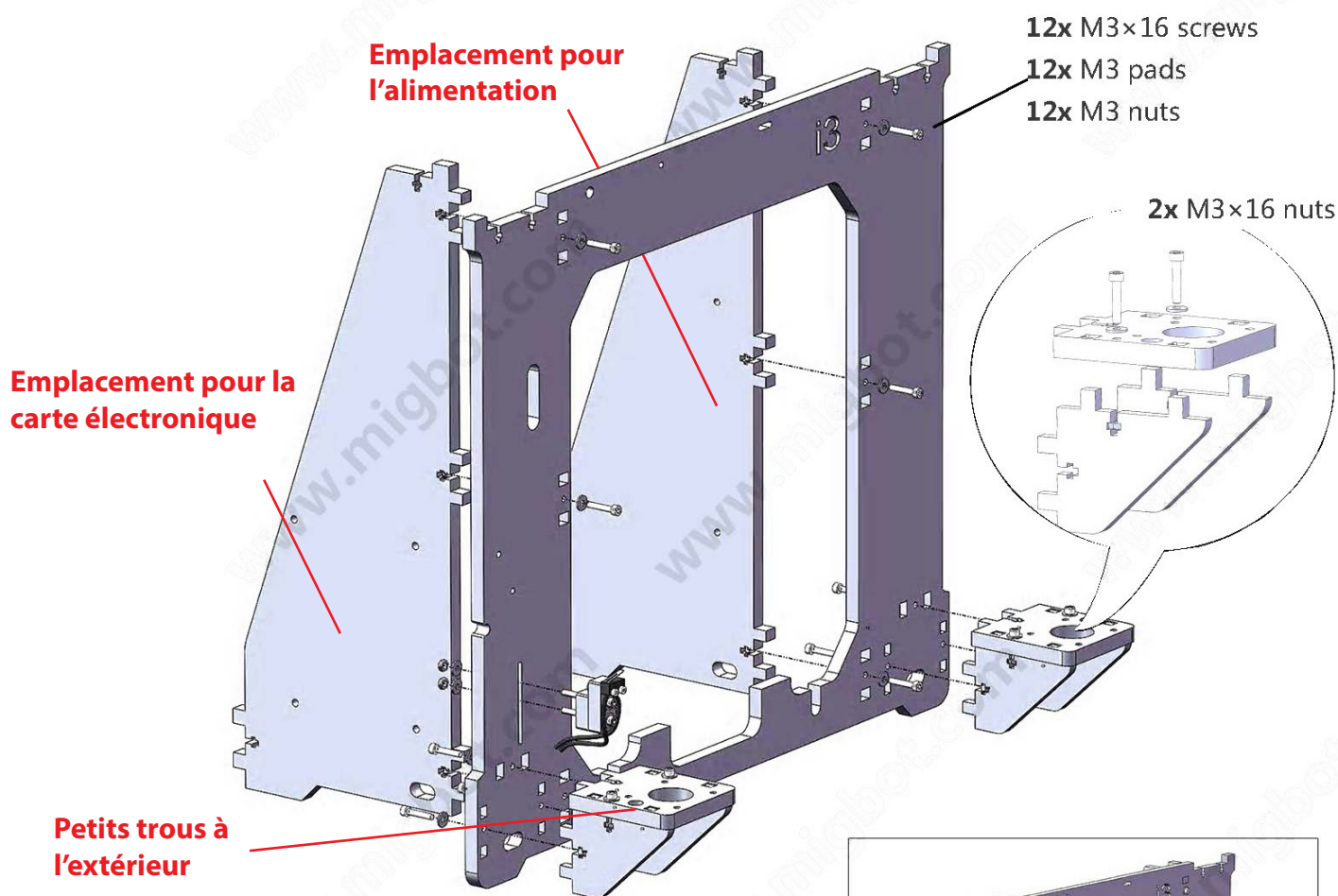

5

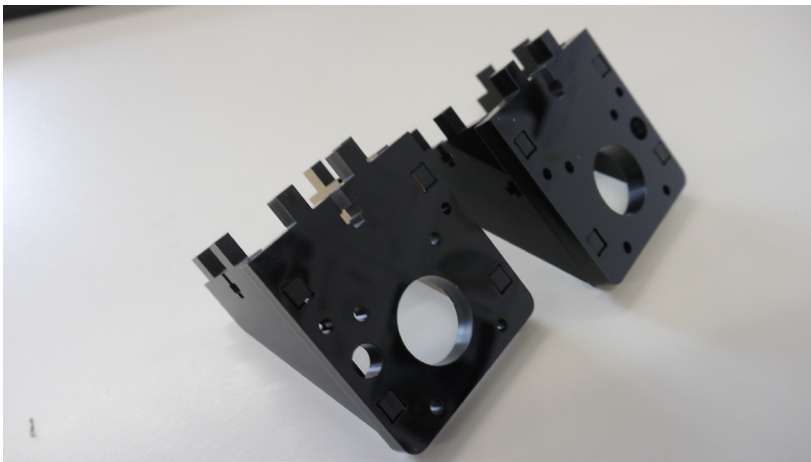

**Préparez les supports moteur sans trop serrer les vis**

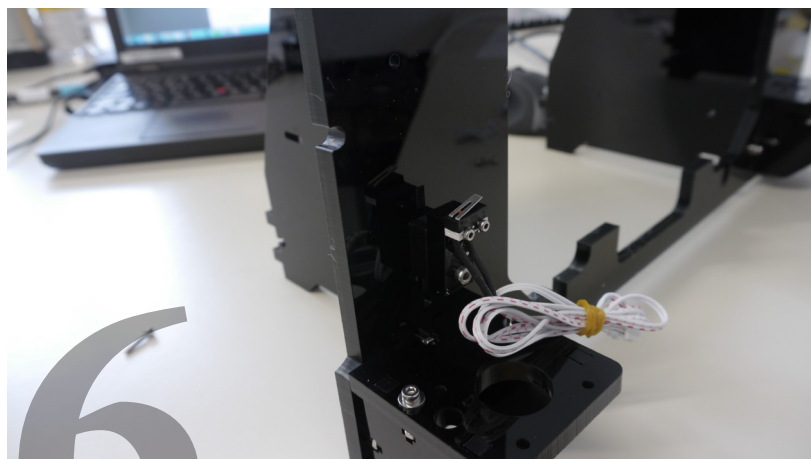
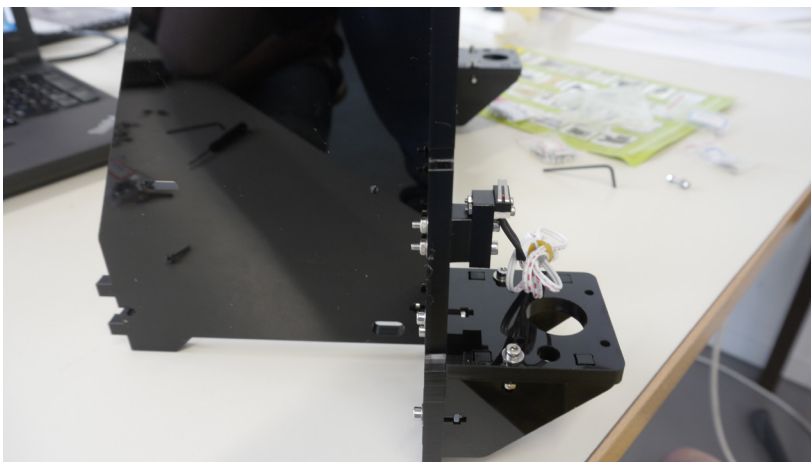
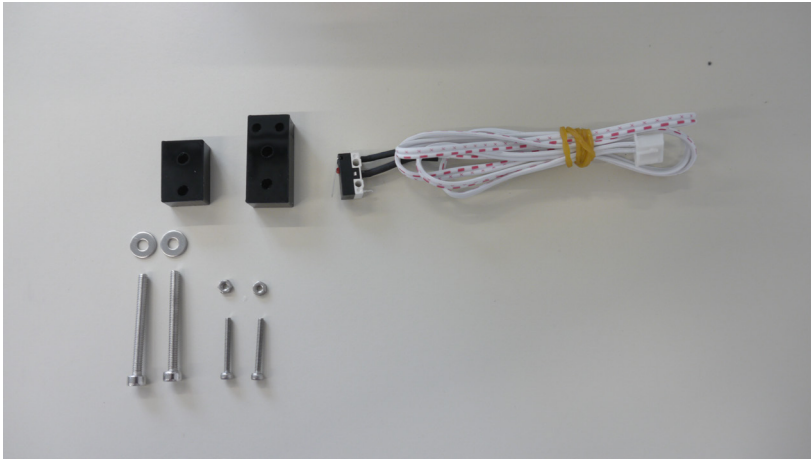

6



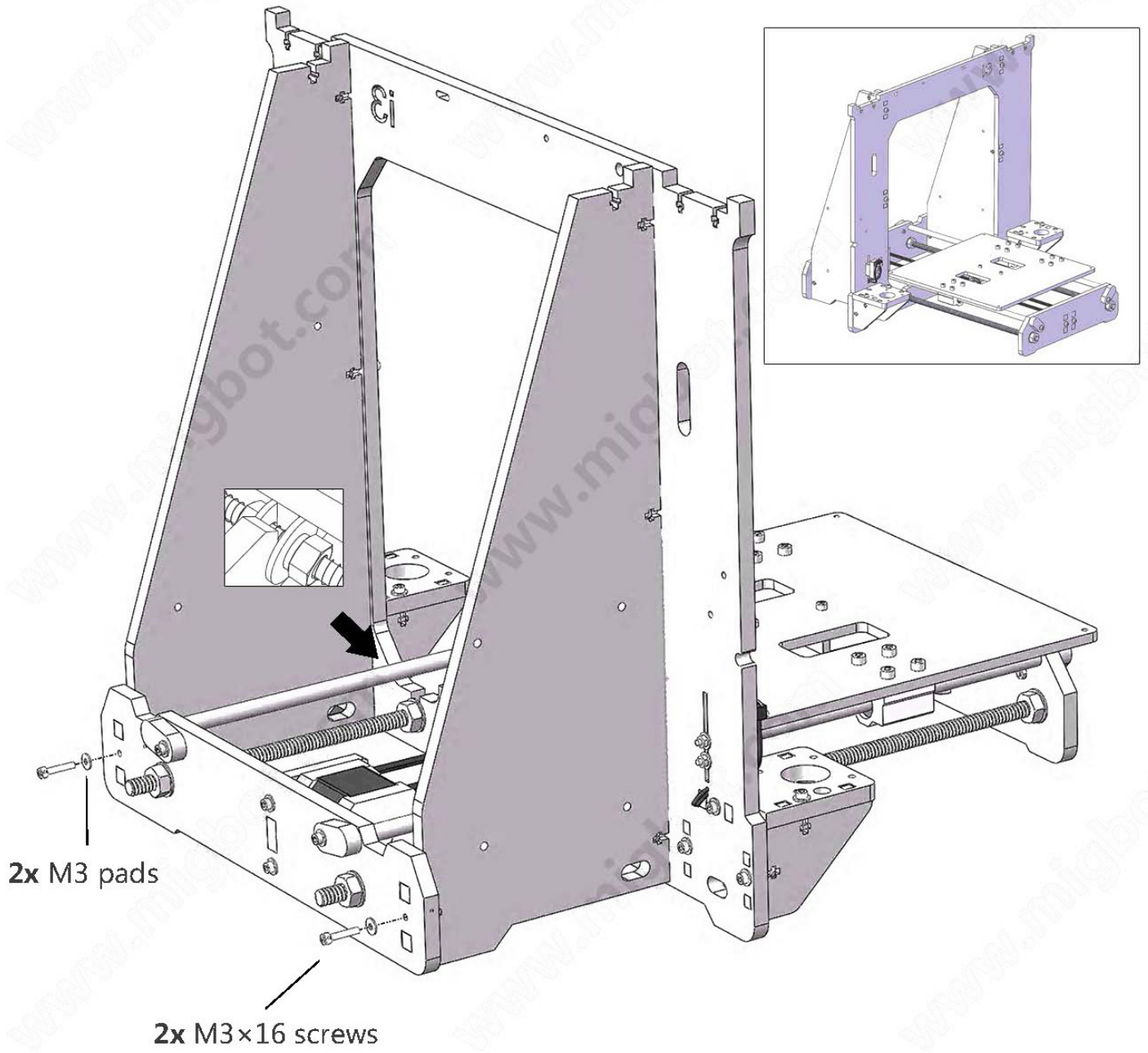

2x M3 pads

2x M3x16 screws

2x M3 x 16mm + écrous + rondelles

7

4x M3×12 screws

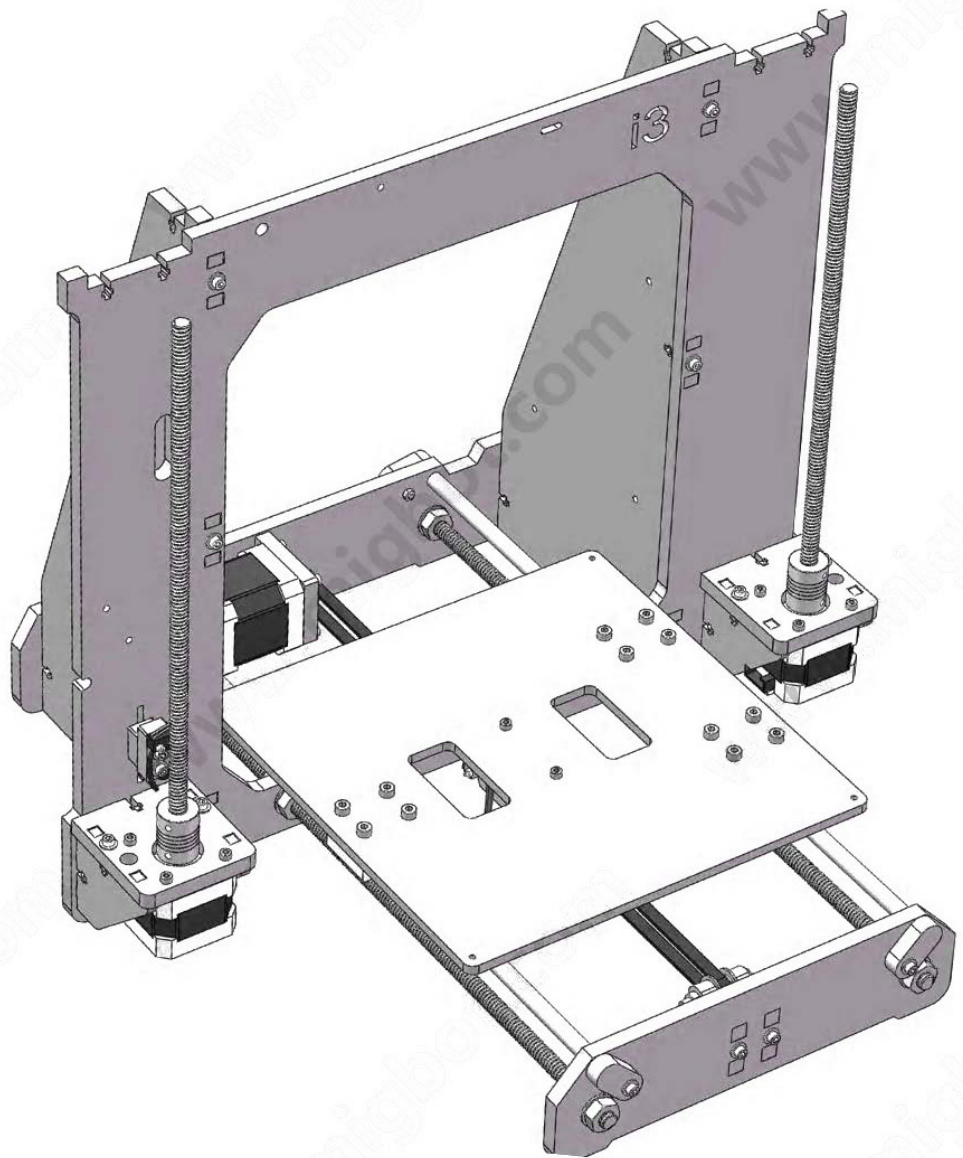
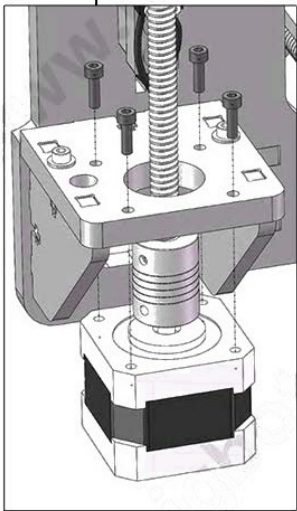

**8x M3 x 12mm (s'il n'est pas possible de  
serrer correctement, une rondelle est  
nécessaire)**

8

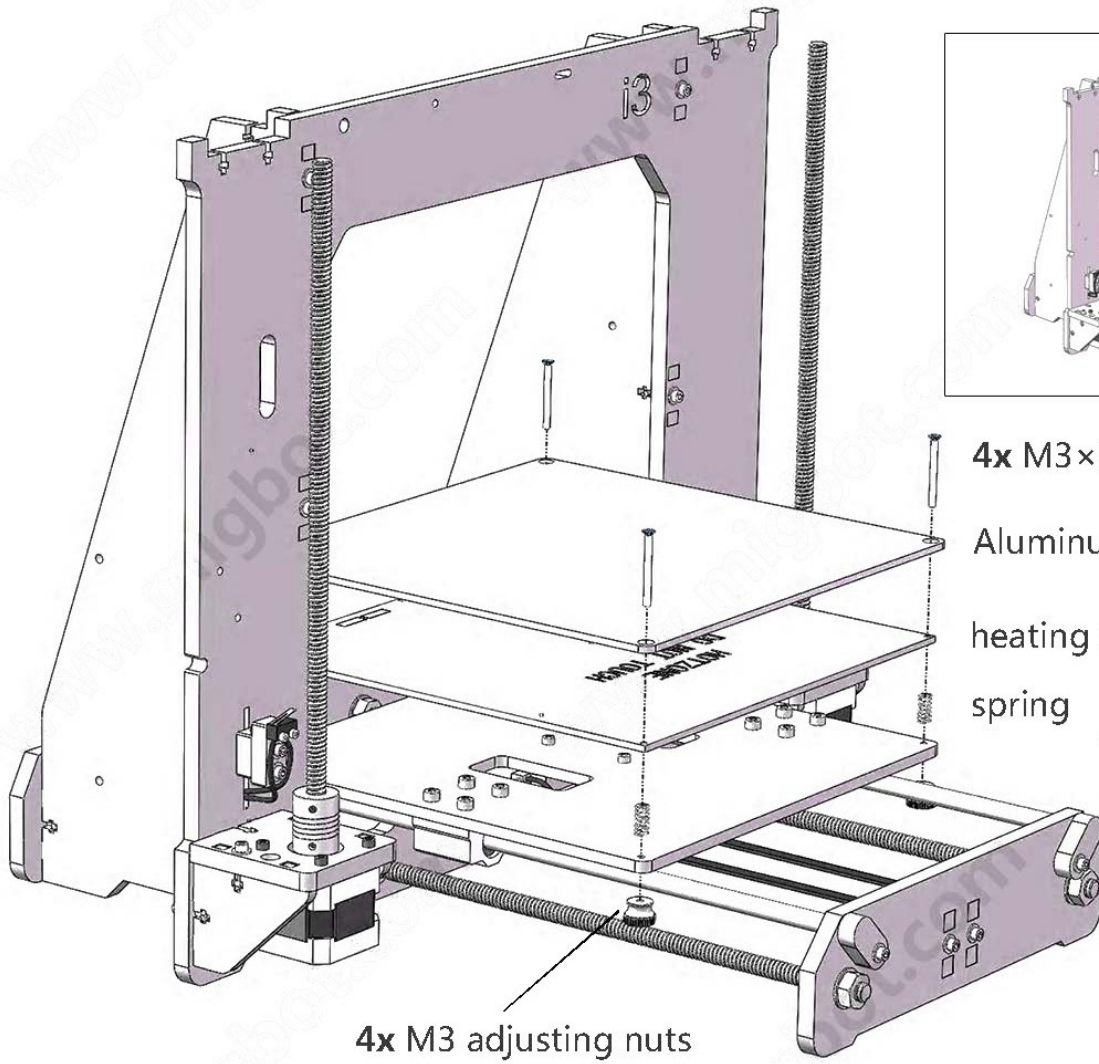

4x M3 x 30mm  
4x ressorts  
4x écrous d'ajustement



9



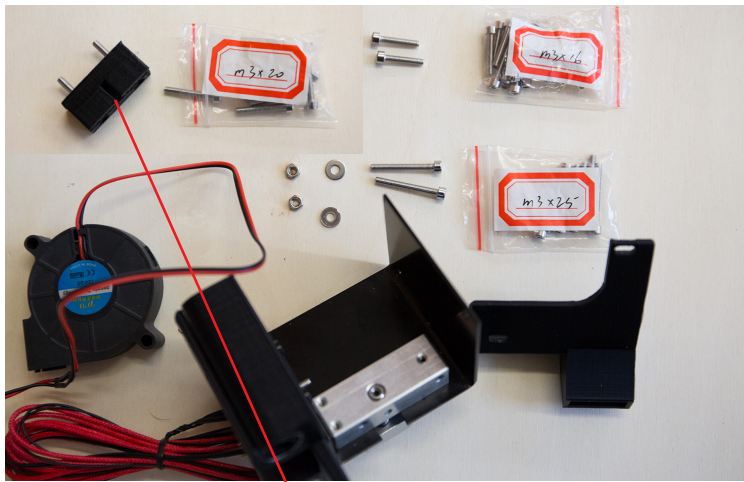

2x M3 x 25mm + rondelles + écrous  
 2x M3 x 20  
 2x M3 x 16mm

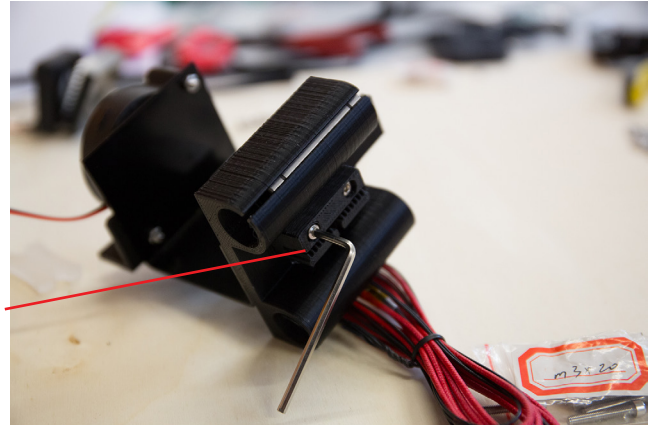

**Fixez premièrement le support de la courroie**

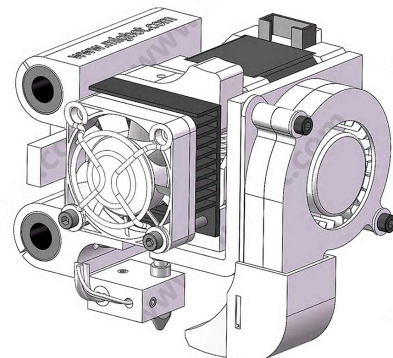
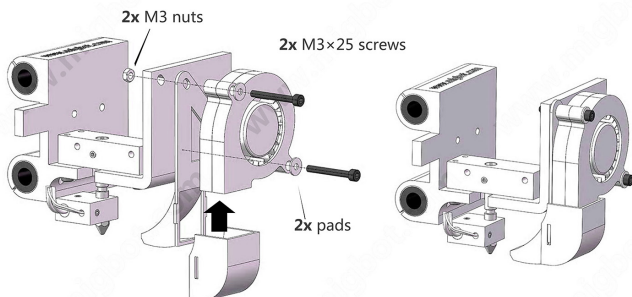
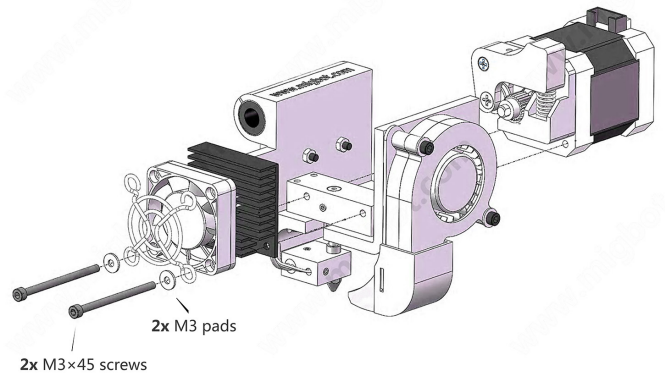
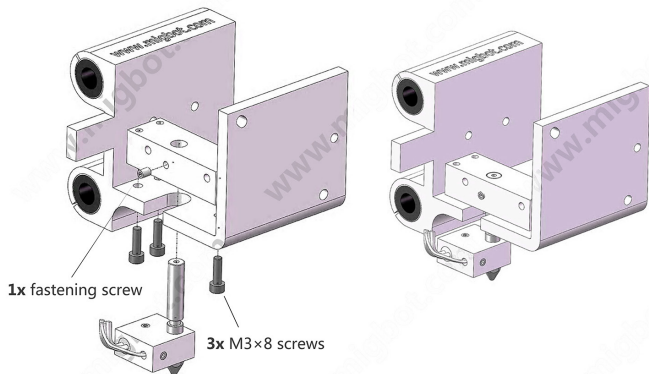
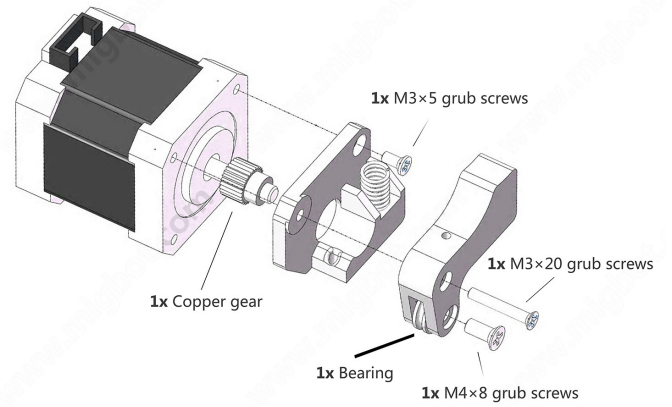
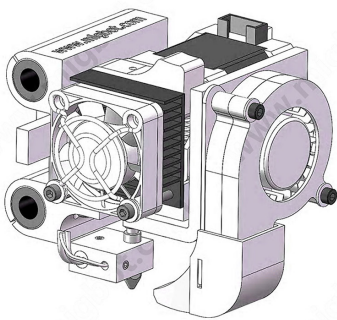

10

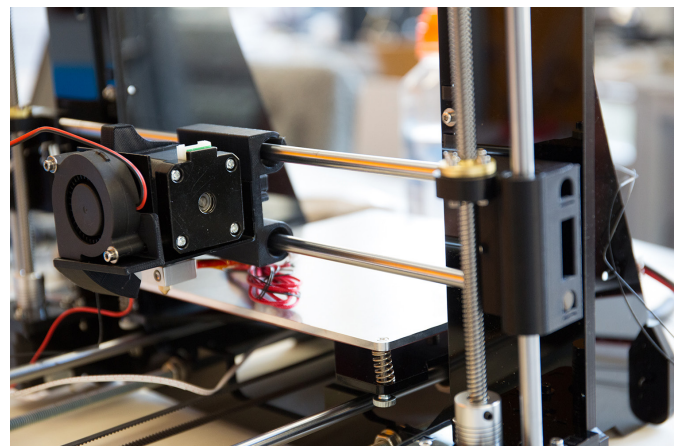
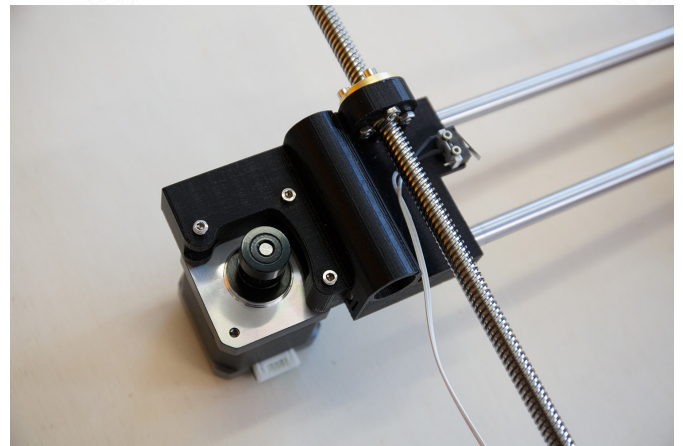
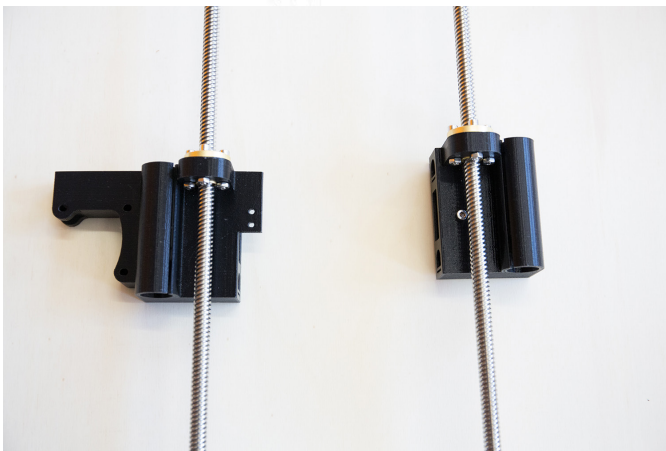
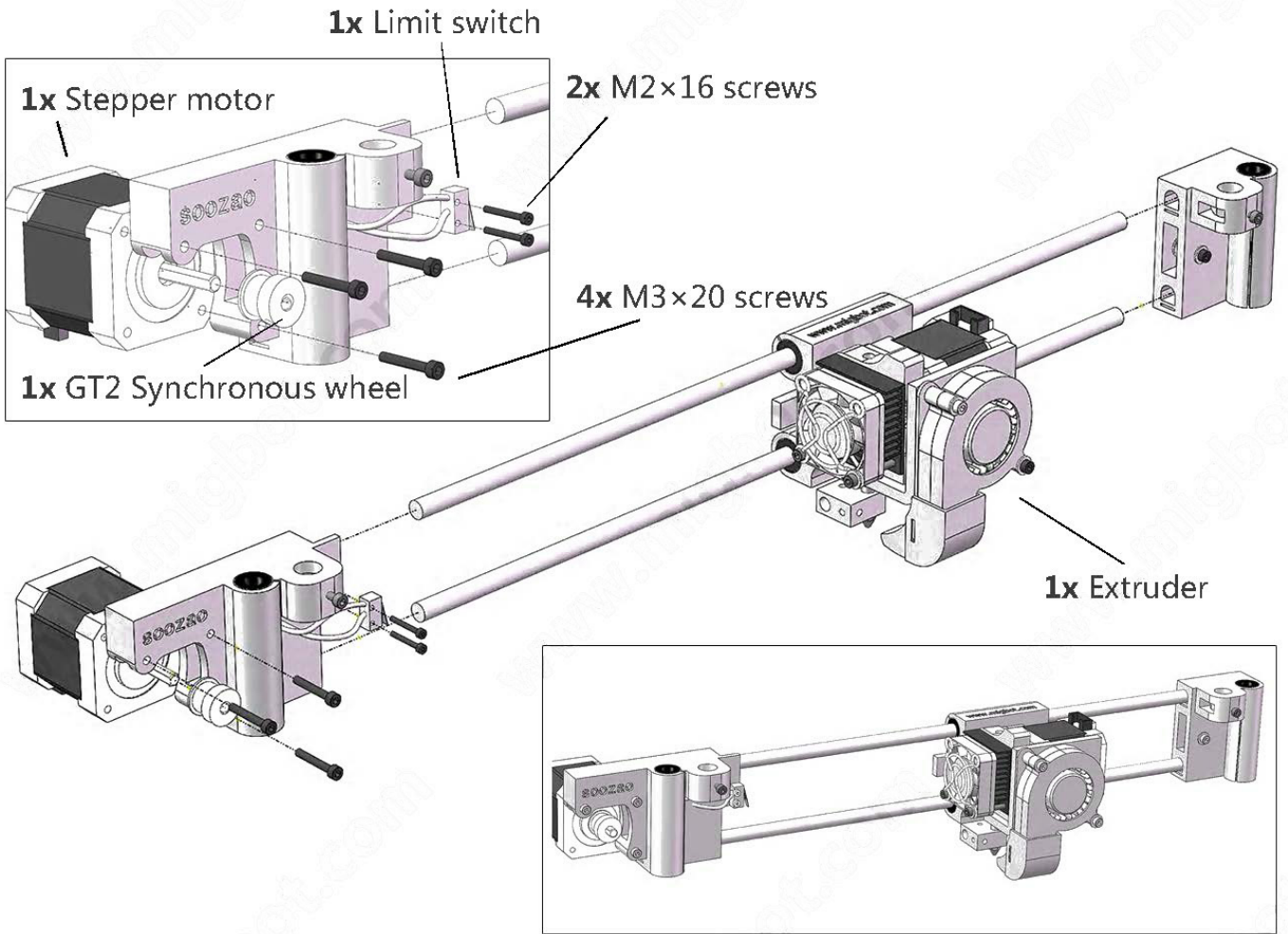

11



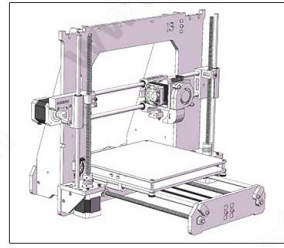
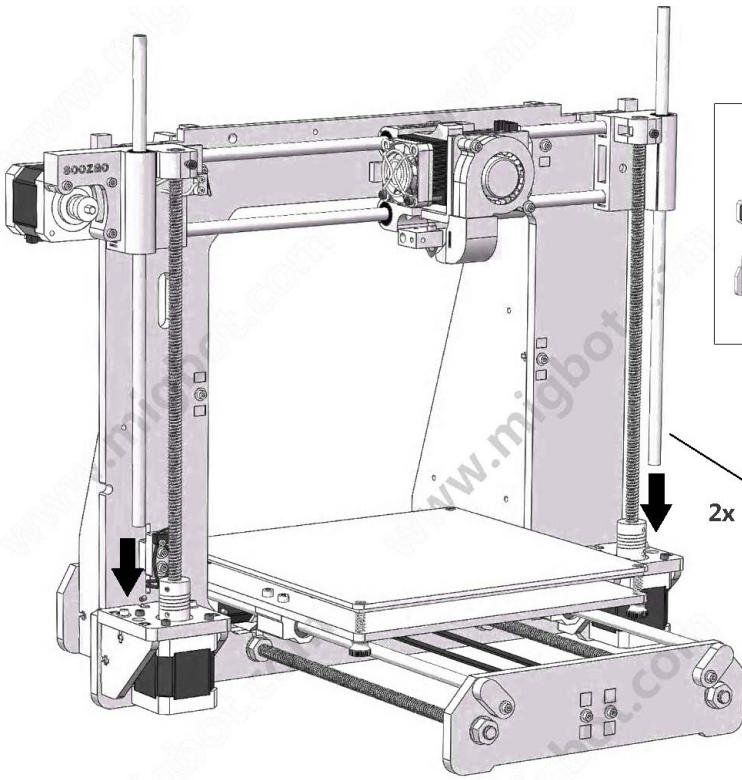

2x φ8×300 polish rod

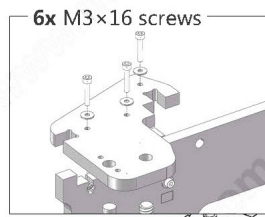

6x M3×16 screws

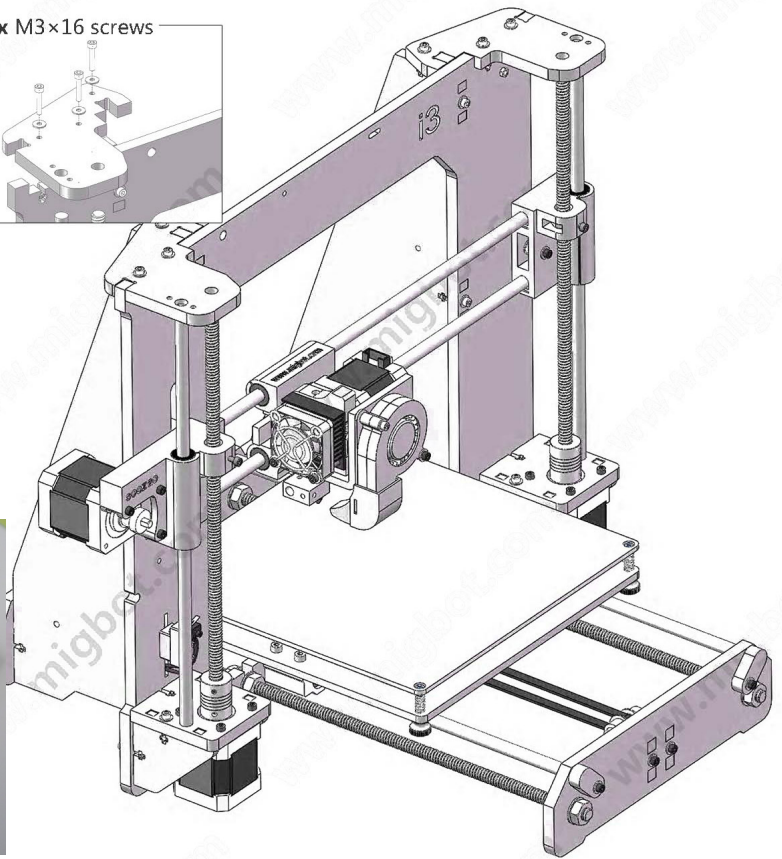

12



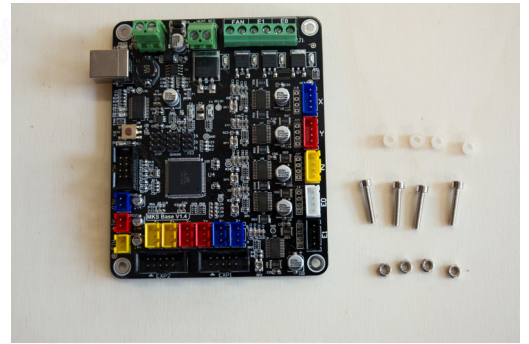
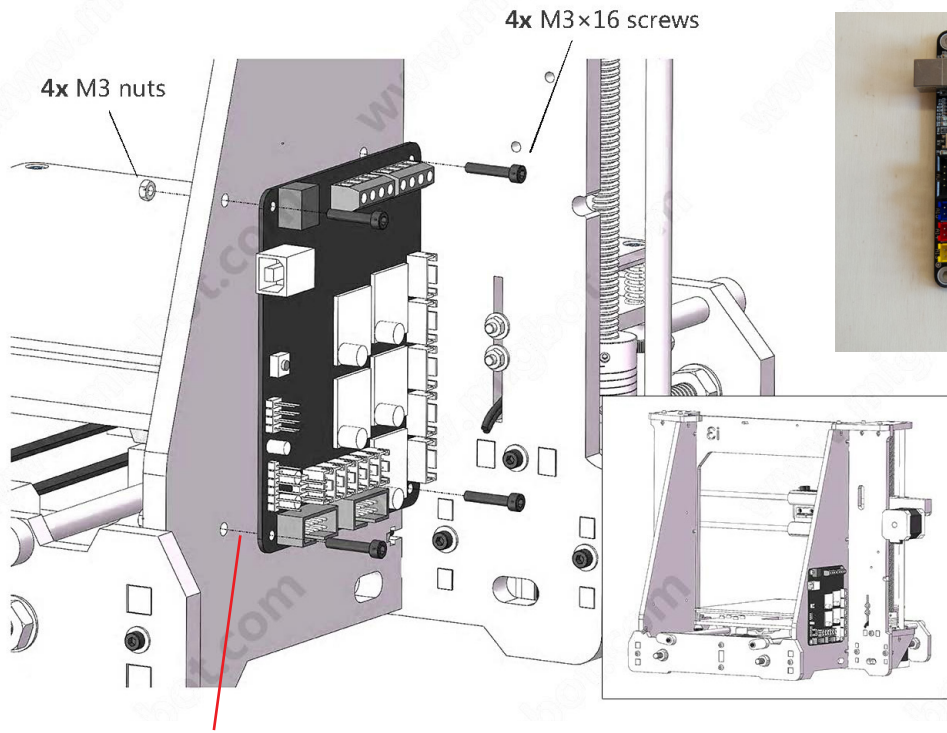

**Placez des entretoises**

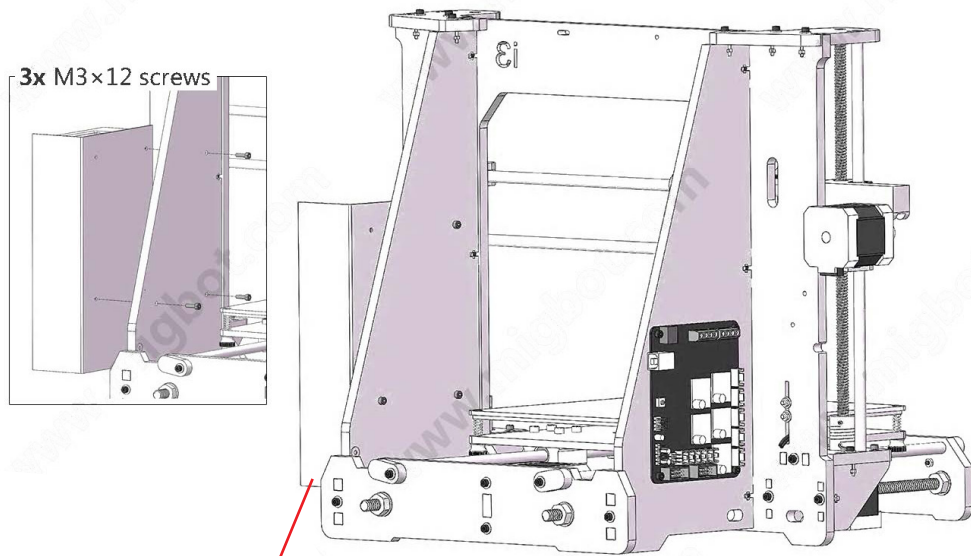

**Connectiques contre le bas**

13

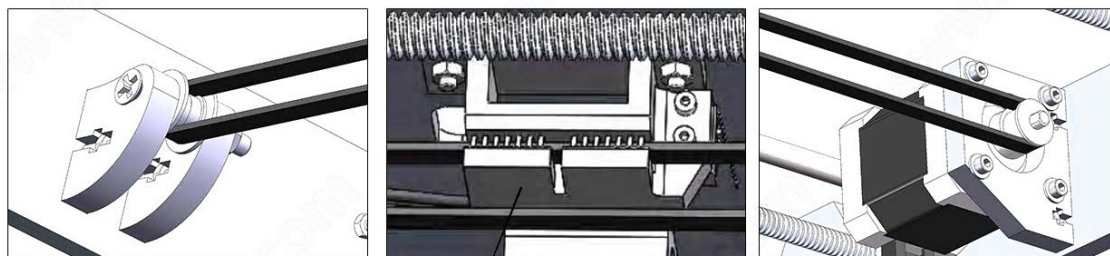
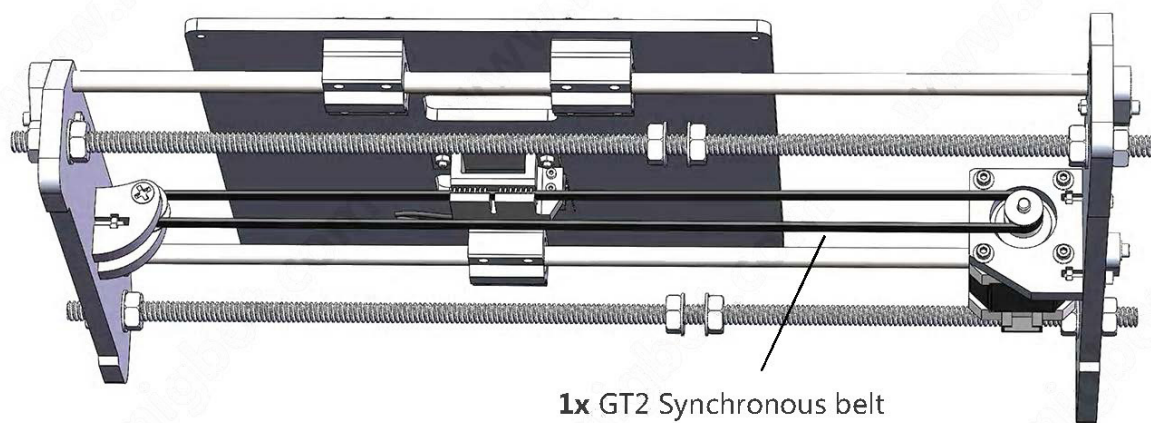
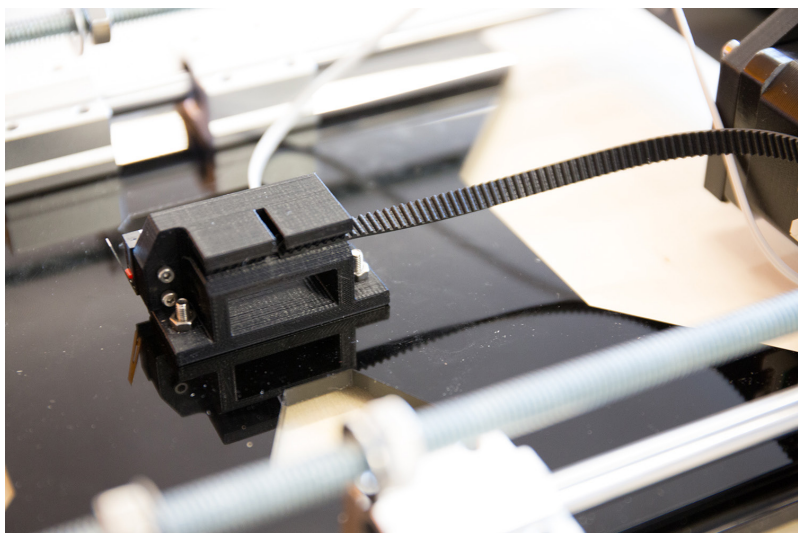

Both ends of the synchronous belt

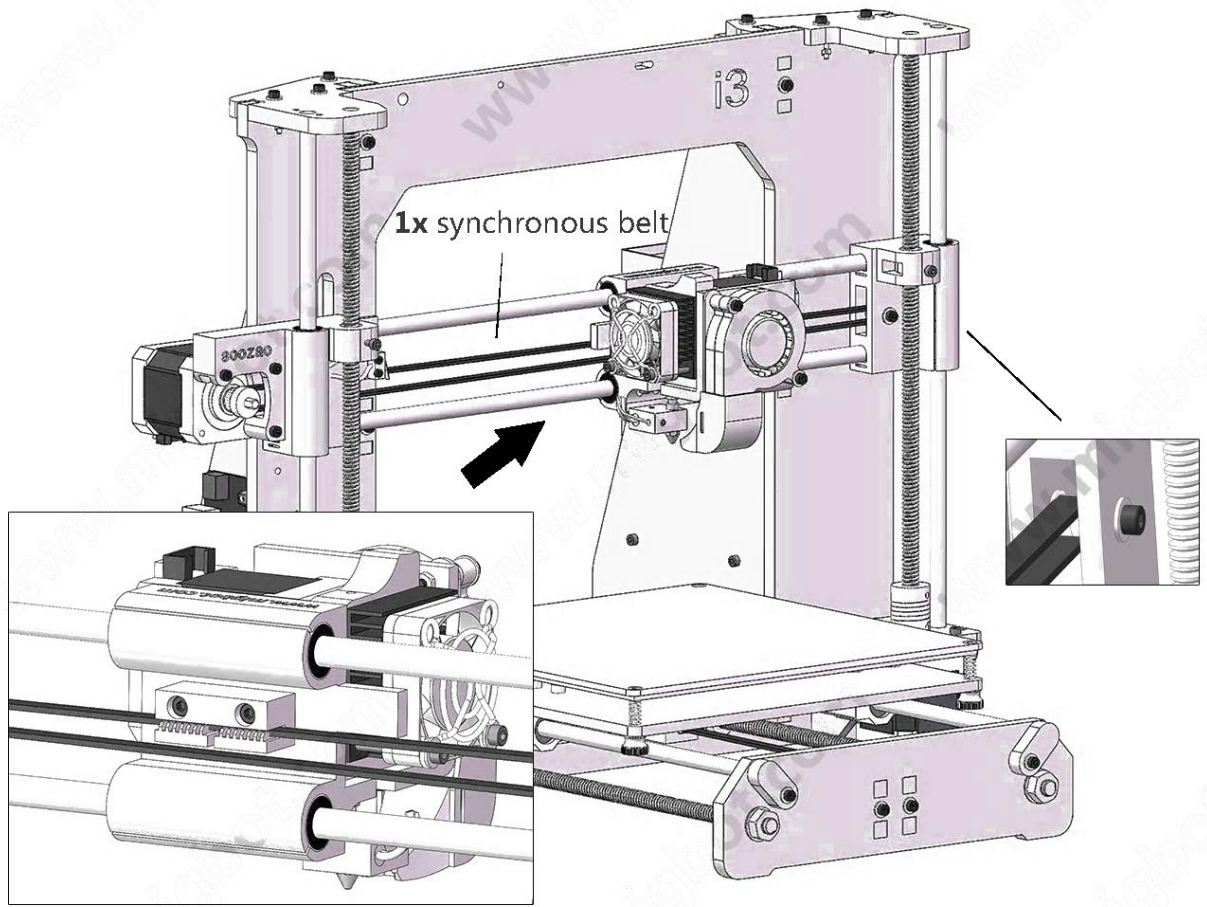

15



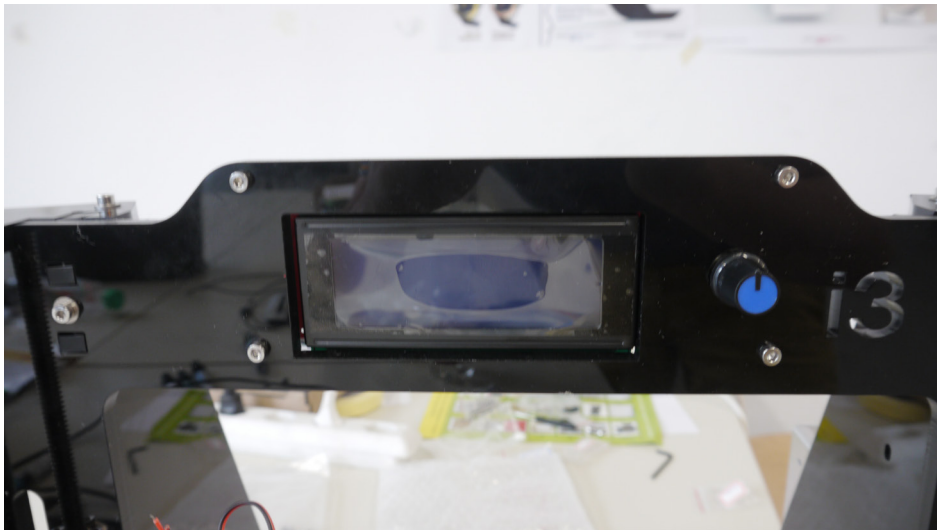
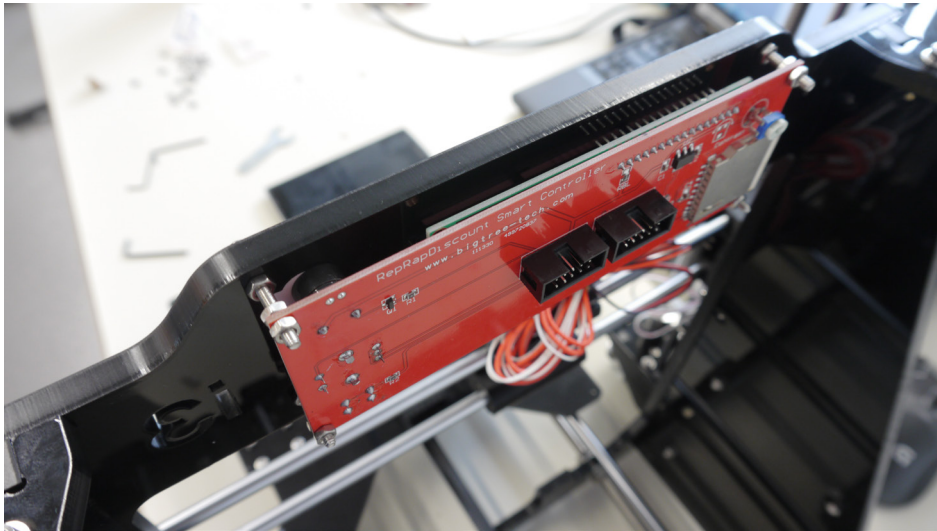
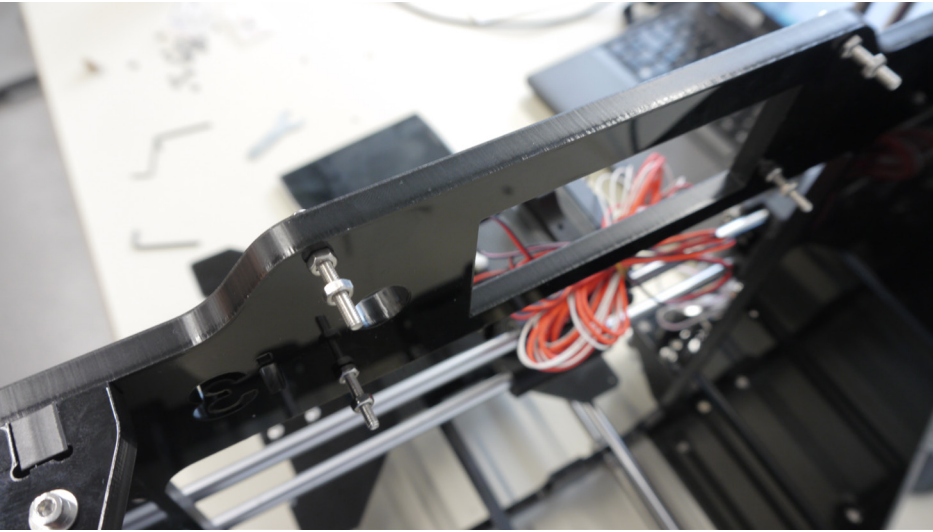

16

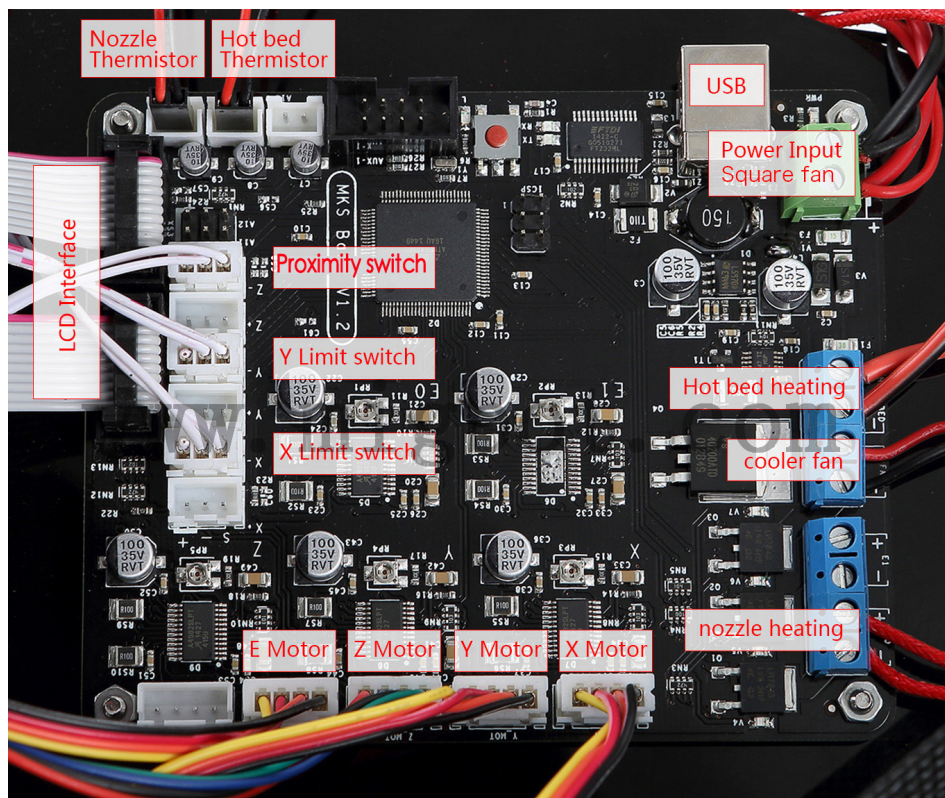
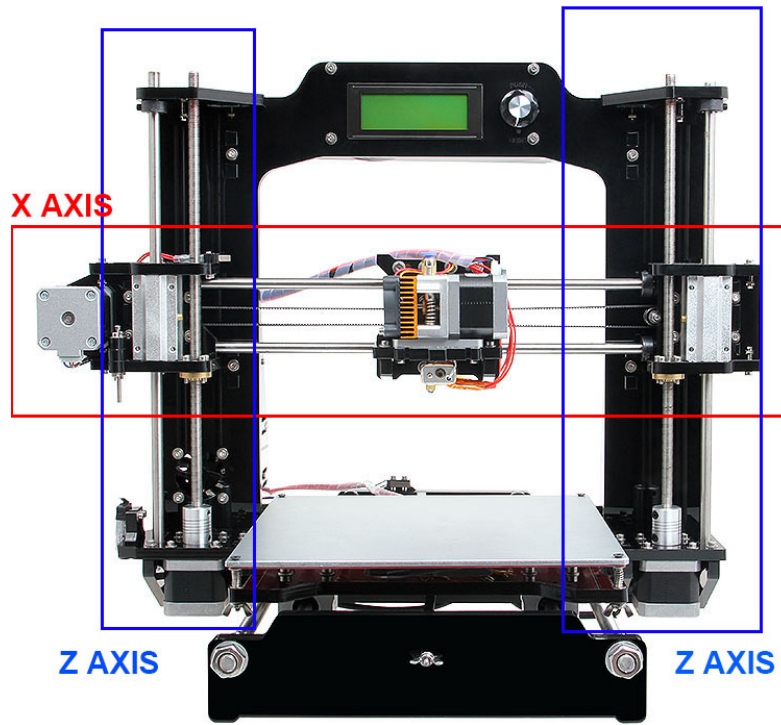

17